



User Manual

SNC5.12kWh-1



Content

1. Modified List	2
2. Preface	3
3. Limitation of Liability.....	3
4. Cautions	4
5. Others.....	4
6. Product Introduction.....	5
7. Battery Introduction	6
8. Battery installation.....	8
9. System wiring	11
10. Power on and off sequence	17
11. LCD screen display and settings	18
12. LED indicator instructions.....	22
13. Maintenance.....	23



2. Preface

- All information in this document is the property of the battery manufacturer. No part of this document may be reproduced in any commercial manner. Allow internal use.
- The battery manufacturer makes no express or implied warranties or guarantees, including but not limited to any implied warranties of utility, commercialization, or suitability for any specific purpose, regarding this document or any devices or software that may be described in this document. Explicitly deny all such statements or warranties. Under no circumstances shall the equipment manufacturer or its distributors or distributors be liable for indirect, incidental or consequential losses.
- According to certain regulations, the exclusion of implied warranties may not apply, therefore the above exclusion may not apply.
- The specifications in this document are subject to change without prior notice. We have made every effort to make this document complete, accurate, and up-to-date. However, device manufacturers may need to make some improvements in certain situations without prior notice. The equipment manufacturer shall not be liable for any losses caused by this document, including but not limited to omissions, printing errors, arithmetic errors, or errors listed in this document.

3. Limitation of Liability

- The equipment manufacturer shall not be liable for any direct or indirect liability for battery system damage or property damage caused by the following circumstances.
- Without authorization from the device manufacturer, the battery system has been modified, modified, or replaced with components.
- Non-equipment manufacturer technicians can change or clear the battery system serial number.
- The design and installation of the system composed of other devices do not comply with standards, safety regulations, and other related requirements.
- Battery damage caused by failure to comply with the requirements of the battery system user manual.
- Battery damage caused by improper or misuse of the battery system.
- Battery damage caused by insufficient ventilation in the battery system.
- The maintenance procedures for the battery system did not follow acceptable standards.
Battery damage caused by force majeure, such as earthquakes, storms, lightning, overvoltage, fires, etc.
- Battery damage is caused by any external factors.



4. Cautions

To prevent the possibility of the power from leaking, heating, firing or exploding, Please be sure to follow the following rules:

- Do not disassemble or alter the outside structure of the power.
- Do not short-circuit the pack by directly connecting the positive and negative terminal with metal object such as wire.
- Do not transport and store the battery together with metal objects such as necklaces, hairpins etc.
- Do not strike or throw the pack.
- Do not strike at pack with any sharp edge parts, and pierce the pack with a nail or other sharp object.
- Do not immerse the power in water and seawater.
- Do not use and leave the power near a heat source as fire, heater, for example, at strong direct sunlight or a vehicle in extremely hot conditions etc.
- Do not use it in a location where static electricity is great, otherwise, the safety devices in the pack may be damaged, which will cause hidden trouble of safety.
- In case of a short circuit, impact or fall of the battery, the battery shall be immediately marked and isolated, and the continued use of the battery shall be prohibited, Even if the battery appears to function normally.
- If the power takes off an odor, generates heat, becomes discolored or deformed, or in any way appears abnormal during use, recharging or storage, immediately remove it from the device or battery charge and stop using it.
- If the power leaks and the electrolyte gets into the eyes, do not rub eyes, instead, rinse the eyes, with clean running water, and immediately seek medical attention. Otherwise, eye injury can result.

5. Others

- Please read and follow the handling instructions for the battery before use. Improper use of the battery may cause heat, fire, rupture, damage or capacity deterioration of the battery.
- The customer is requested to contact Sunnew Energy in advance, if and when the customer needs other applications or operating conditions than those described in this document. Additional experimentation may be required to verify performance and safety under such conditions.
- Sunnew Energy will take no responsibility for any accident when the battery is used under other conditions than those described in this Document.
- Sunnew Energy will inform, in a written form, the customer of improvements regarding proper use and handling of the battery, if it is deemed necessary.
- Any matters that this specification does not cover should be conferred between the customer and Sunnew Energy.

6. Product Introduction

6.1 Description

This product is made of high-quality lithium battery as the main energy storage, high cycle life and uses the spray of cold rolled steel sheet as the enclosure, the built-in battery intelligent management system, higher reliability, to provide comprehensive communication function, is compatible with all kinds of mainstream brands in the market inverter. The product is widely used in various energy storage scenarios and fields.

6.2 Symbol Description

Symbol	Describe
	There is a potential danger after the equipment is running. Please take protective measures when operating the equipment.
	There is high voltage during the operation of the equipment. When operating the equipment, please ensure that it has been powered off.
	Please use the equipment reasonably. In extreme cases, there is a risk of explosion.
	The equipment contains corrosive electrolyte. Please avoid contact with leaked electrolyte or volatile gases.
	Before operating the equipment, please read the product manual carefully.
	Pay attention to personal protection during installation, operation, and maintenance.
	Equipment should be kept away from open flames or ignition sources.
	The equipment should be kept away from areas accessible to children.
	At the end of the device's lifespan, do not dispose of it together with household waste.
	The equipment should be placed in the correct place and recycled in accordance with local environmental regulations.
	CE certification mark.
	RCM certification mark.
	Protective grounding sign, used to indicate the connection position of the protective grounding wire.

7. Battery Introduction

7.1 Product size



7.2 Battery panel function diagram

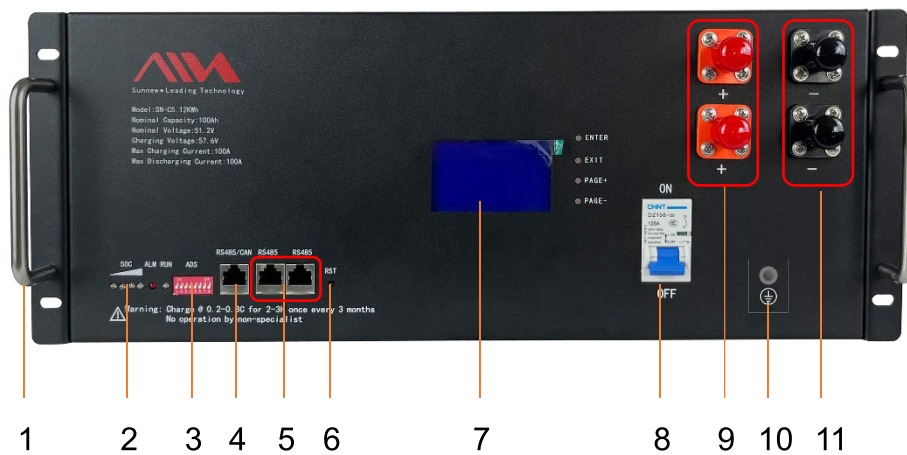

1	Handle	7	LCD Display Screen
2	Power indicator	8	DC Breaker
3	DIP Switch	9	Battery Positive Pole
4	CAN Communication Port	10	Grounding Wire Interface
5	RS485 Parallel Communication Port	11	Battery Negative Electrode
6	Reset Switch		



7.3 Technical specifications

No.	Item	Specification	Remark	
1	Boundary dimension	L442*W430*H178mm		
2	Serial-Parallel Mode	16S1P		
3	Basic parameter	Nominal voltage	51.2 V	
		Typical capacity	100 Ah (5120 Wh)	At 0.2C
		Inner resistance	≤60 mΩ	AC 1kHz
		Working voltage range	43.2~58.4 V	
4	Charging input	Charge method	CC&CV	
		Charge voltage	58.4 V	
		Standard charge current	50 A	
		Max. continuous charge current	100 A@30S	
5	Discharging output	Discharge cut-off voltage	43.2 V	
		Standard discharge current	50 A	
		Max. continuous discharge current	100 A@30S	
6	Main shell material	SPCC		
7	IP class	IP43		
8	Cooling method	Air cooling		
9	Net weight	Approx 45kg		
10	Environmental requirement	Operation temperature range	Charge: 0°C~45°C Discharge: -20°C~55°C	
		Storage temperature range	15°C~25°C: ≤12 Months 0°C~35°C: ≤3 Months -20°C~45°C: ≤1 Months	
		Storage humidity	15%-85%RH	



8. Battery installation

8.1 Installation precautions

Before installing and using energy storage batteries, it is necessary to carefully read the product technical manual and installation instructions, and strictly follow the requirements for installation operations. During installation, special attention should be paid to the following points:

- 1) The installation plan should be designed according to the location, area, and surrounding environment, such as ventilation environment, sunlight exposure. For batteries placed outdoors, special attention should be paid to objective factors such as waterproofing, sun protection, and dust prevention.

Attention: The installation position of the battery should avoid direct sunlight, avoid being close to heat sources, and avoid using it in humid or high-temperature environments. The battery is most suitable for use in an ambient temperature range of 20 ° C to 25 ° C, otherwise it will affect the battery's service life.

- 2) Before installation, inspect the appearance of the battery to see if there is any leakage, if the casing is damaged, and if the open circuit voltage is normal. When handling batteries, be careful not to bump them and take protective measures.
- 3) The battery is shipped in a charged state and must be handled with care to avoid short circuits. Insulated tools and gloves should be worn during installation to prevent electric shock.
- 4) At the end of installation, the positive and negative voltage of the battery should be checked again to ensure that it is not damaged during installation.
- 5) After installation, clean the battery case, cover, panel, and connecting wires with a clean, dry, and soft cloth. Do not use organic solvents to clean to avoid corrosion of the battery case cover and other components. At the same time, clean the installation site and take away any waste generated during the installation process, paying attention to ventilation, dust prevention, and waterproofing.

8.2 Product and accessory list

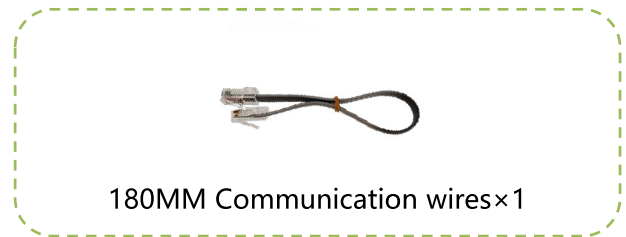

8.3 Installation steps

Note: Selection of installation location

According to the principle listed in the first point of "Precautions", choose a sturdy and flat ground to install this product, and ensure that the battery has at least 200MM of heat dissipation space.





1) Cabinet installation

Conventional cabinet installation can directly install the battery on a standard 4U cabinet.



2) Stacked installation

Schematic diagram of various installation methods and steps

<p>Step 1: Remove the battery and place it on a flat surface.</p>	
<p>Step 2: Remove the screws that need to tighten the bracket position</p>	
<p>Step 3: Install the bracket.</p>	
<p>Step 4: According to the screw space on the bracket, tighten the screws provided.</p>	
<p>Step 5: Repeat steps 1-4 to install all the required battery brackets, stack them together as shown in the picture, and lock the locking buckle.</p>	

9. System wiring

9.1 System diagram

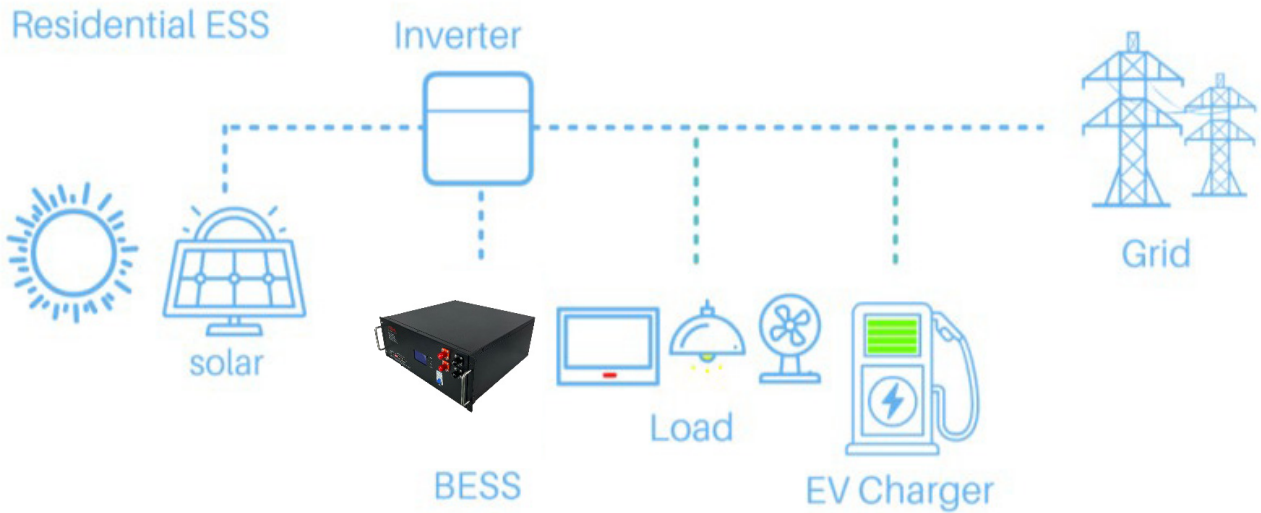

9.2 Ground wire connection

- ⚠ **Note:** When installing equipment, the protective ground wire must be installed first; When dismantling equipment, the protective ground wire must be removed last.
- ⚠ **Note:** The pulling force after crimping should be greater than 400N.
- ⚠ **Note:** Connect one of the two ground wires and reserve the other.
- ⚠ **Note:** Cross section area of protective ground wire conductor: 5mm^2 . The wire must comply with outdoor usage standards.

1) Crimp grounding terminal

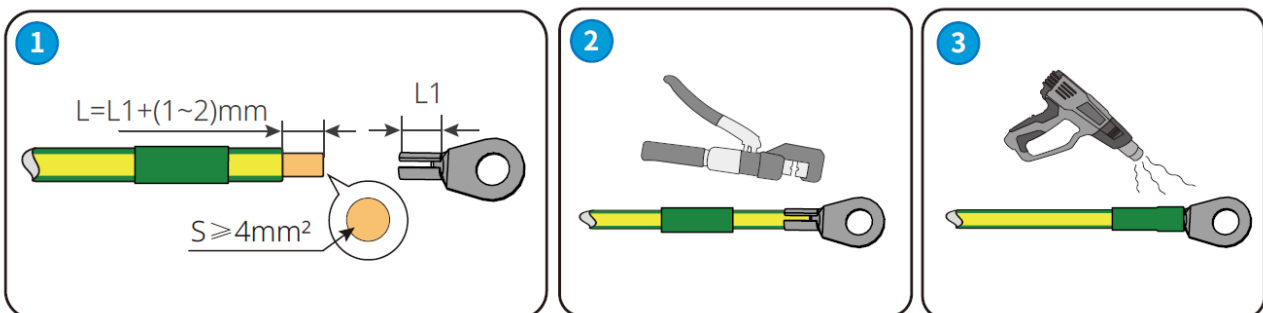

2) Connect the ground wire to the battery



9.3 Power wire connection

- ⚠ Wire Size: 6AWG
- ⚠ All wiring must be performed by a professional person.
- ⚠ All battery pack switches must be disconnected during installation.
- ⚠ Use a suitable screwdriver to unscrew the bolts and fit the battery connectors in, then fasten the bolt by the screwdriver, making sure the bolts are tightened with a torque of 24.5 N.M in the clockwise direction.
- ⚠ Before making the final DC connection or closing DC breaker/disconnect, be sure positive (+) must be connected to positive (+) and negative (-) must be connected to negative (-). A reverse polarity connection on the battery will damage the inverter.

Please use Inverter connection power wires to connect the battery to the inverter, as shown in the figure below.



9.4 Communication connection

Please use the communication wires we provide for the communication connection, as shown in the figure below.



Note: Please refer to the instruction manual of the relevant brand inverter for the communication interface between the inverter and the battery.



RJ45 connector definition

RJ45 Registered Jack

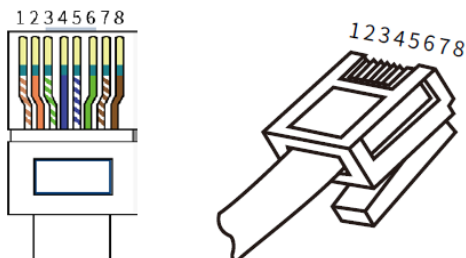

CAN communication interface

PIN	Definition
1、8	RS485-B
2、7	RS485-A
4	CAN-H
5	CAN-L
3、6	GND

9.5 Parallel connection of batteries

Parallel schematic diagram

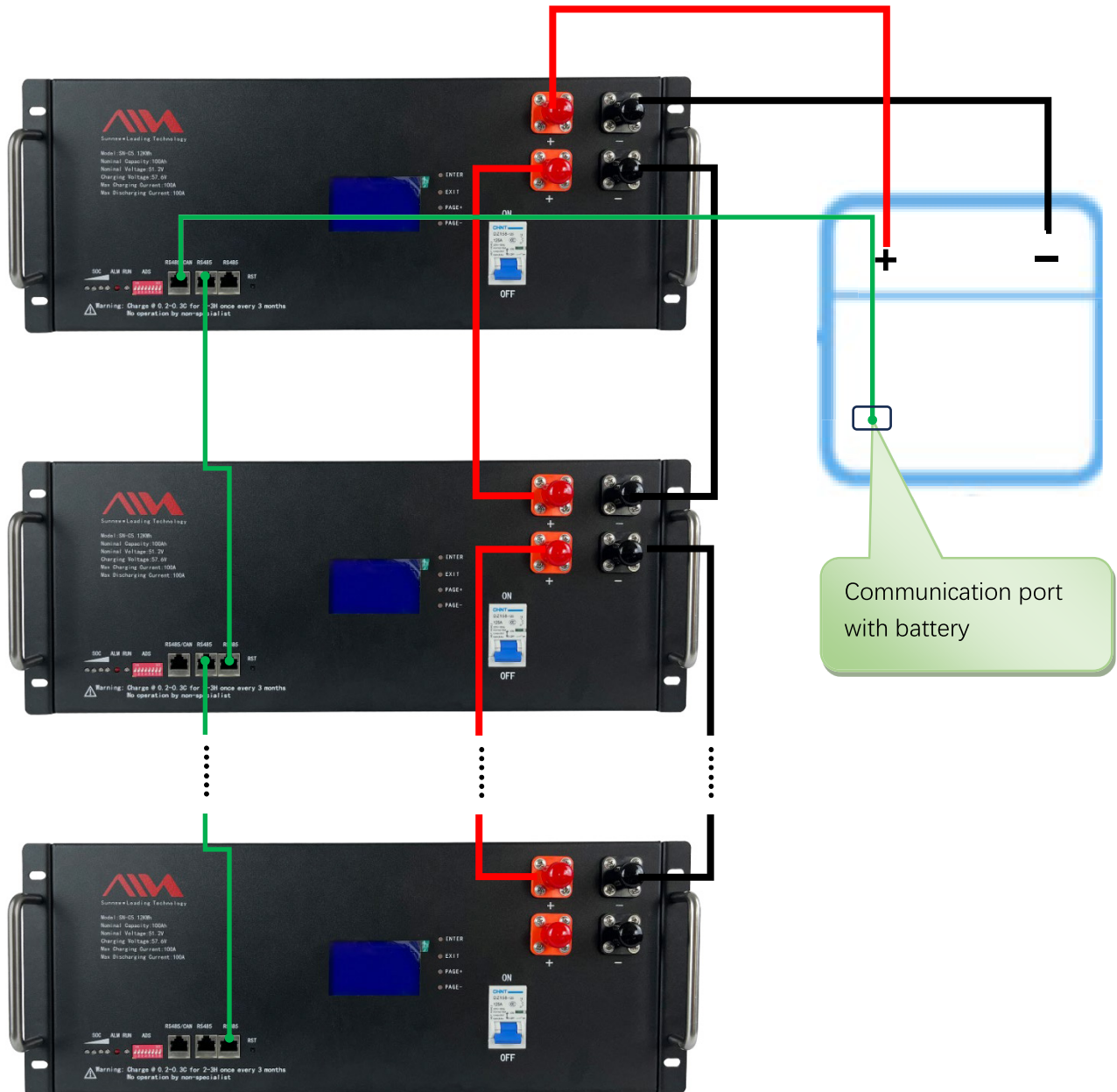

Note: Supports up to 16 sets of batteries in parallel

9.6 Dialing address selection (manual dialing method)

Definition of parallel DIP switch: In multi-machine communication when the battery pack is in parallel, the DIP switch is used to distinguish different pack addresses, and the hardware address can be set through the DIP switch on the board.

Definition of dial switches bit1 to bit8: bit1 to bit4 are used to set the address, and bit5 to bit8 are used for the number of slaves.

Host settings: Bit1 to Bit4 are set to 0, the host address is fixed to 0, and Bit5 to Bit8 are set based on the number of parallel slaves. (As shown in Table 2)

Slave settings: Bit1 to Bit4 are set according to the device order, with a range of slave addresses from 1 to 15. Bit5 to Bit8 are fixed to 0. (As shown in Table 1)

Parallel use address setting: For the definition of DIP switches, refer to the following table.

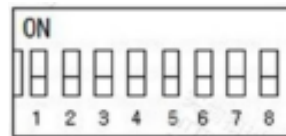

Slave settings (Table 1)

address	DIP switch position				illustrate
	#1	#2	#3	#4	
1	ON	OFF	OFF	OFF	Pack1
2	OFF	ON	OFF	OFF	Pack2
3	ON	ON	OFF	OFF	Pack3
4	OFF	OFF	ON	OFF	Pack4
5	ON	OFF	ON	OFF	Pack5
6	OFF	ON	ON	OFF	Pack6
7	ON	ON	ON	OFF	Pack7
8	OFF	OFF	OFF	ON	Pack8
9	ON	OFF	OFF	ON	Pack9
10	OFF	ON	OFF	ON	Pack10
11	ON	ON	OFF	ON	Pack11
12	OFF	OFF	ON	ON	Pack12
13	ON	OFF	ON	ON	Pack13
14	OFF	ON	ON	ON	Pack14
15	ON	ON	ON	ON	Pack15

Master settings (Table 2)

number	DIP switch position				illustrate
	#5	#6	#7	#8	
2	ON	OFF	OFF	OFF	2 parallel machines
3	OFF	ON	OFF	OFF	3 parallel machines
4	ON	ON	OFF	OFF	4 parallel machines
5	OFF	OFF	ON	OFF	5 parallel machines
6	ON	OFF	ON	OFF	6 parallel machines
7	OFF	ON	ON	OFF	7 parallel machines
8	ON	ON	ON	OFF	8 parallel machines
9	OFF	OFF	OFF	ON	9 parallel machines
10	ON	OFF	OFF	ON	10 parallel machines
11	OFF	ON	OFF	ON	11 parallel machines
12	ON	ON	OFF	ON	12 parallel machines
13	OFF	OFF	ON	ON	13 parallel machines
14	ON	OFF	ON	ON	14 parallel machines
15	OFF	ON	ON	ON	15 parallel machines

9.7 Automatic dialing method

The automatic dialing connection diagram is as follows:

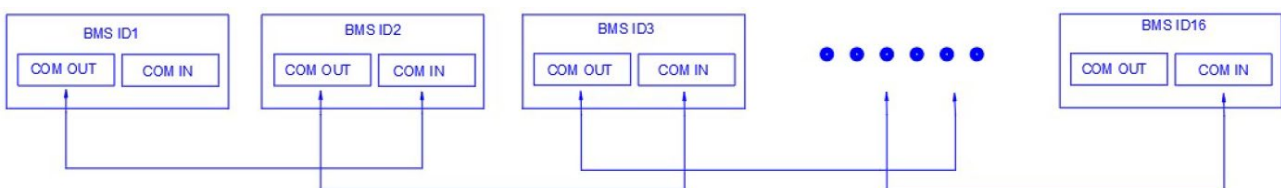

Note: Supports up to 16 sets of batteries in parallel

10. Power on and off sequence

Power on: Press and hold the “Reset Switch” button on the front panel for about 1 second, then the LCD, work indicator lights up, and a beep is heard, and the machine will complete the boot operation.

Note: Due to the characteristics of the machine, after booting, the system will generally stabilize the output within 5~10 seconds; When booting, please turn on the battery first, and then turn on the load.



1 . Press and hold the “Reset Switch” button on the front panel for about 1 second

2 . Close the circuit breaker

Power off: First turn off the load, then disconnect the circuit breaker, and finally turn off the battery switch, At this time, the LCD and work indicator lights will go out, and a beep sound will be heard. The machine will complete the shutdown operation.



2 . Press and hold the "Reset Switch" button on the front panel for about 6 seconds until all 6 LED lights turn on and then off to complete the shutdown

1 . Disconnect the circuit breaker

11. LCD screen display and settings

11.1 Main page

After power on activation, the battery management interface will be displayed, and press the Enter key to enter the main page. As shown in the following figure:

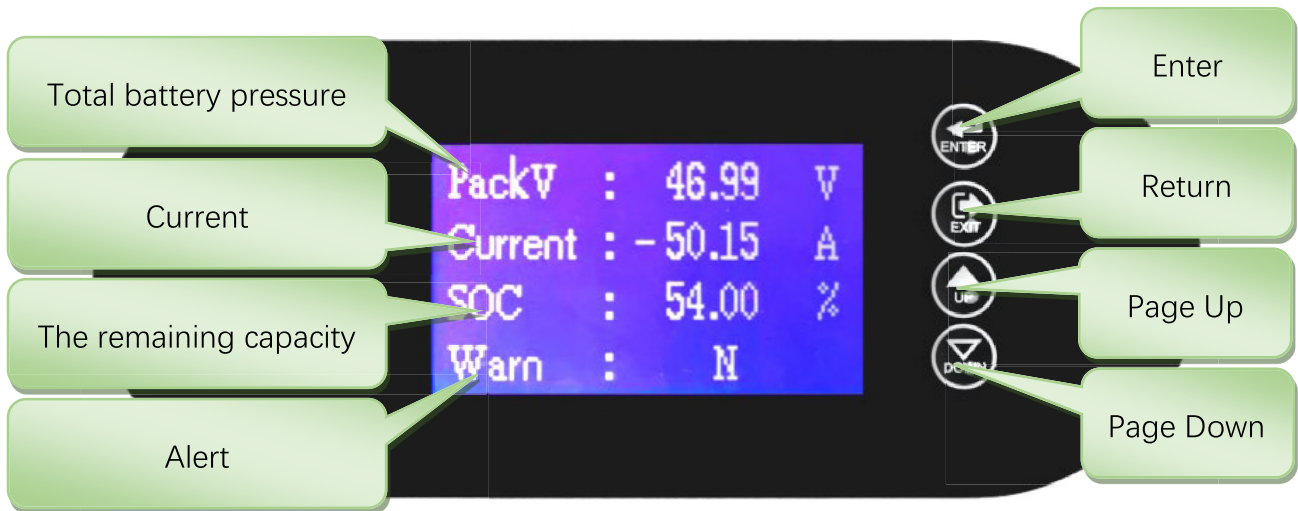

Note: Long press the confirm button to switch between Chinese or English display

11.2 Battery parameter interface

Press "Enter" or "Down" to enter detailed battery parameter information

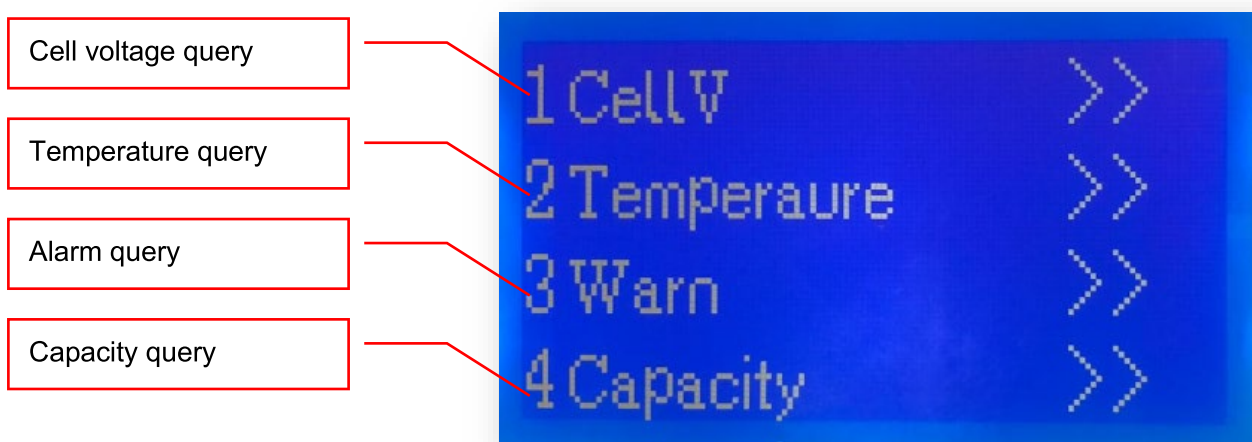

11.3 Status alarm

High voltage warning	» OV-Warn:	N
Oversvoltage protection	--OV-Prot:	N
Low-voltage warning	--UV-Warn:	N
Undervoltage protection	--UV-Prot:	N

High temperature warning	» OT-Warn:	N
Over temperature protection	--OT-Prot:	N
Low temperature warning	--UT-Warn:	N
Under-temperature protection	--UT-Prot:	N

Overcurrent warning	» OC-Warn:	N
Overcurrent protection	--OC-Prot:	N
Remaining capacity alarm	--CAPA-Warn:	N
Failure warning	--OFF-USE:	N

Short circuit protection

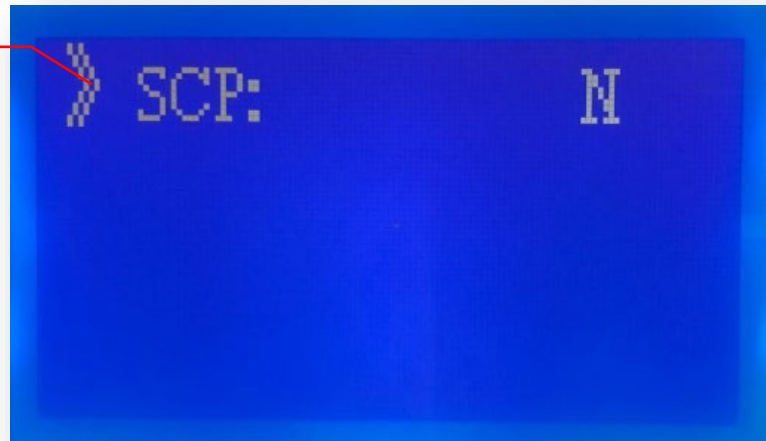

Battery capacity

The remaining capacity

Cycles

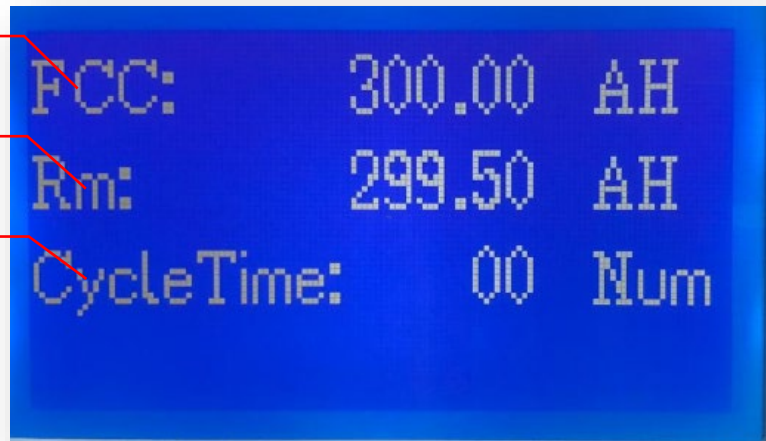

11.4 CAN protocol switching

Press the "down" button on the main page to enter the protocol switching interface, select the corresponding protocol, and long press the "Enter" button for 3 seconds, Jump to SUCCESS, switch completed.

CAN Protocol Page 1

CAN Protocol Page 2

485 Protocol Page 1

485 Protocol Page 2



-->CAN PAGE 1

Pylon protocol

Growatt protocol

Victron protocol

SMA protocol



-->CAN PAGE 2

Ginlong protocol

Studer protocol

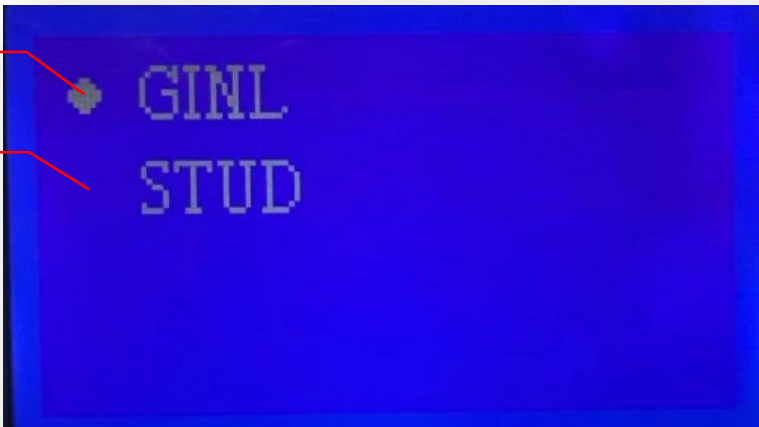

Protocol switch successful

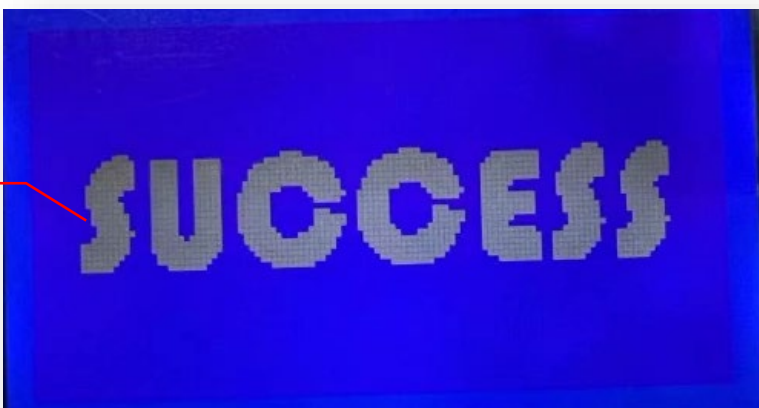

12. LED indicator instructions

12.1 Schematic diagram of LED indicator light positions



12.2 Capacity indication

System status		charge				discharge			
Capacity indicator		L4 ●	L3 ●	L2 ●	L1 ●	L4 ●	L3 ●	L2 ●	L1 ●
Remaining capacity	0 ~ 25%	OFF	OFF	OFF	Flicker	OFF	OFF	OFF	ON
	25 ~ 50%	OFF	OFF	Flicker	ON	OFF	OFF	ON	ON
	50 ~ 75%	OFF	Flicker	ON	ON	OFF	ON	ON	ON
	≥ 75%	Flicker	ON	ON	ON	ON	ON	ON	ON
Running indicator ●		ON				Flicker			

12.3 Light Blink explanation

Flashing mode	ON	OFF
Flash 1	0.25s	3.75s
Flash 2	0.5s	0.5s
Flash 3	0.5s	1.5s

12.4 Status indicator

System status	running state	RUN	ALM	SOC				illustrate
		●	●	●	●	●	●	
Shutdown	dormancy	OFF	OFF	OFF	OFF	OFF	OFF	All OFF
Standby	normal	Flash 1	OFF	OFF	OFF	OFF	OFF	Standby state
charge	normal	ON	OFF	According to battery capacity indication				Highest LED flash 2
	Overcurrent alarm	ON	Flash 2	According to battery capacity indication				Highest LED flash 2
	Overvoltage protection	Flash 1	OFF	OFF	OFF	OFF	OFF	
	Temperature and overcurrent protection	Flash 1	Flash 1	OFF	OFF	OFF	OFF	
discharge	normal	Flash 3	OFF	According to battery capacity indication				According to battery capacity indication
	Alarm	Flash 3	Flash 3	According to battery capacity indication				
	Temperature, overcurrent, short circuit protection	OFF	ON	OFF	OFF	OFF	OFF	Stop discharging, and there is no action force after 48h when the mains is offline dormancy
	Low voltage protection	OFF	OFF	OFF	OFF	OFF	OFF	Stop discharging

13. Maintenance

Maintenance project	Maintenance Cycle
If the battery is not in use, it needs to be fully charged and discharged to 25-50%.	Every 3 months
Check if the wall bracket is installed loose, and if so, tighten the corresponding position.	Every 3 months
Check if the shell is damaged. If so, please repaint or contact the after-sales service center.	Every 3 months
Check if there is any wear on the exposed wires. If there is, please replace the corresponding cable or contact the after-sales service center.	Every 3 months
Check if there is any debris accumulation around the battery. If there is, please clean it to avoid affecting the battery's heat dissipation.	Every 3 months
Check for water or pests to avoid long-term battery intrusion.	Every 3 months



- ⚠ If you find a problem that may affect the battery system, please contact the after-sales personnel and do not disassemble it privately.
- ⚠ If the copper wire inside the conductive wire is exposed, it is forbidden to touch, high voltage danger, please contact the after-sales personnel, it is forbidden to disassemble without permission.
- ⚠ In case of other emergencies, please contact the after-sales personnel as soon as possible, operate under the guidance of the after-sales personnel, or wait for the after-sales personnel to operate on-site.



Professional Manufacturer of Energy Storage Batteries